

CENTER PIN DIAMETER:  $\phi$  0.65mm

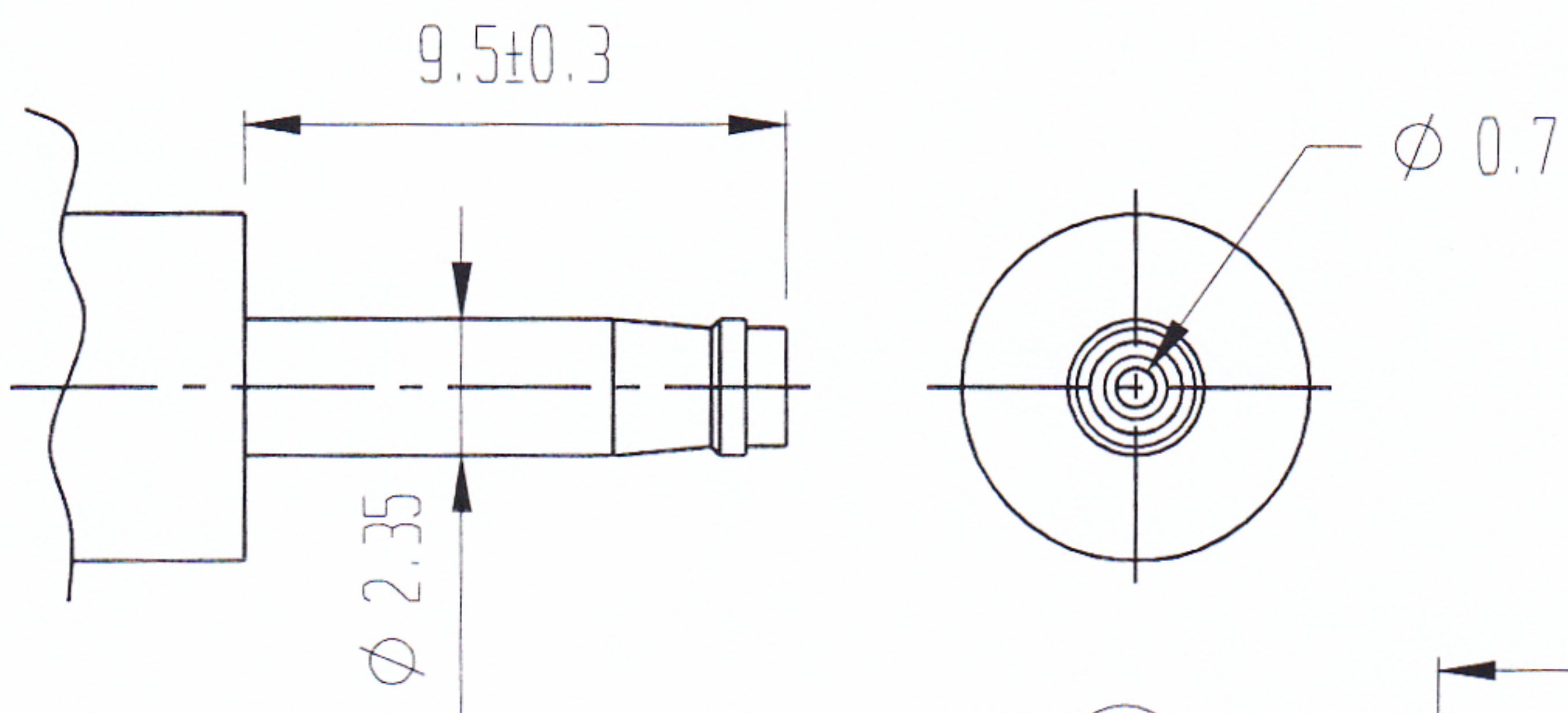

RoHS  
Compliance

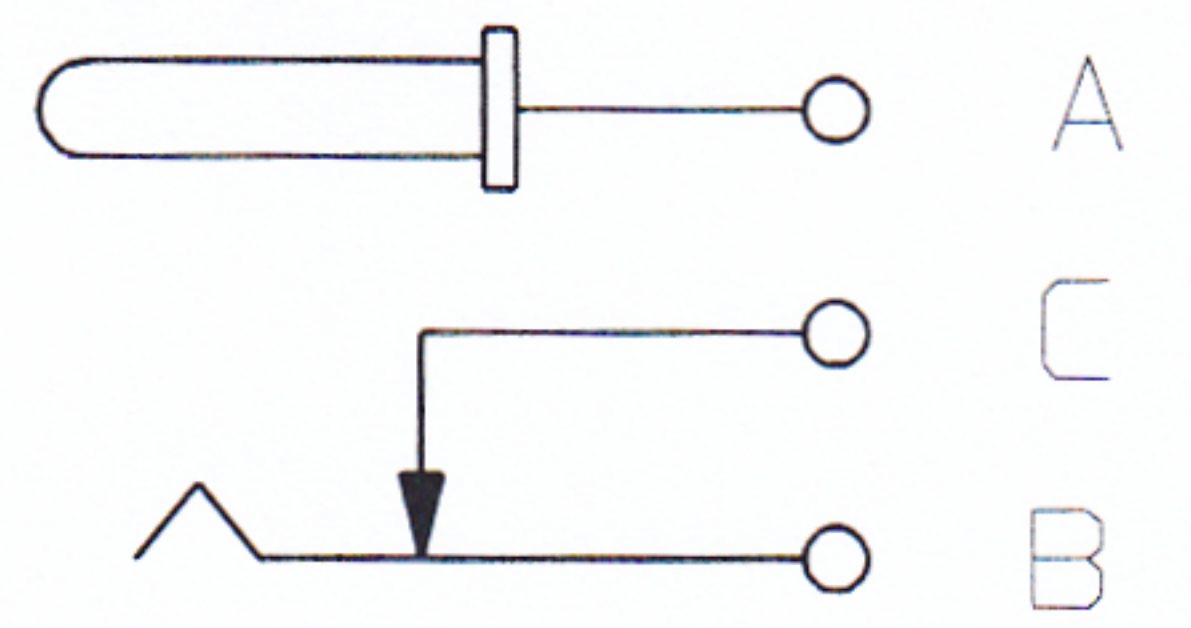

SCHEMATIC

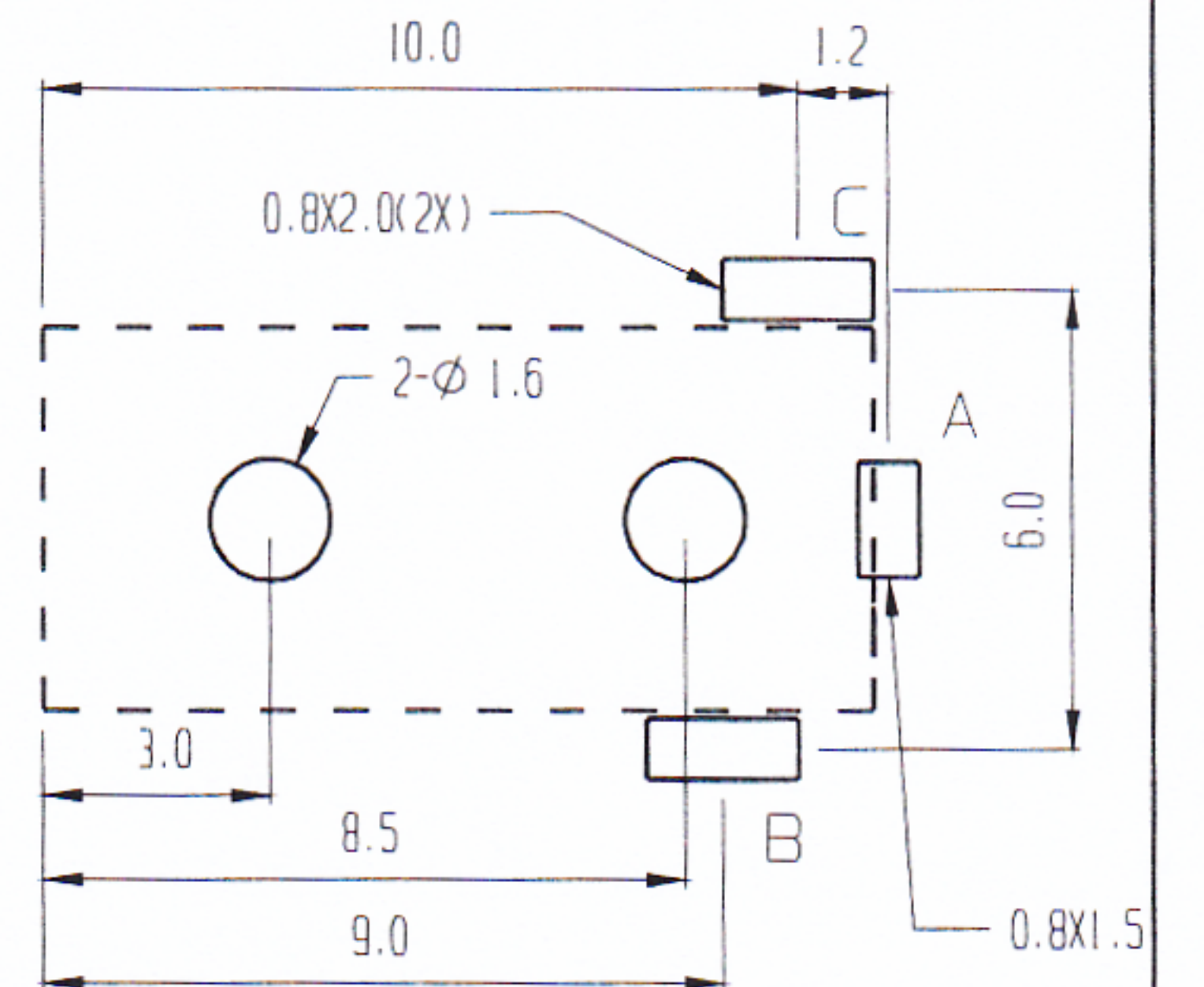
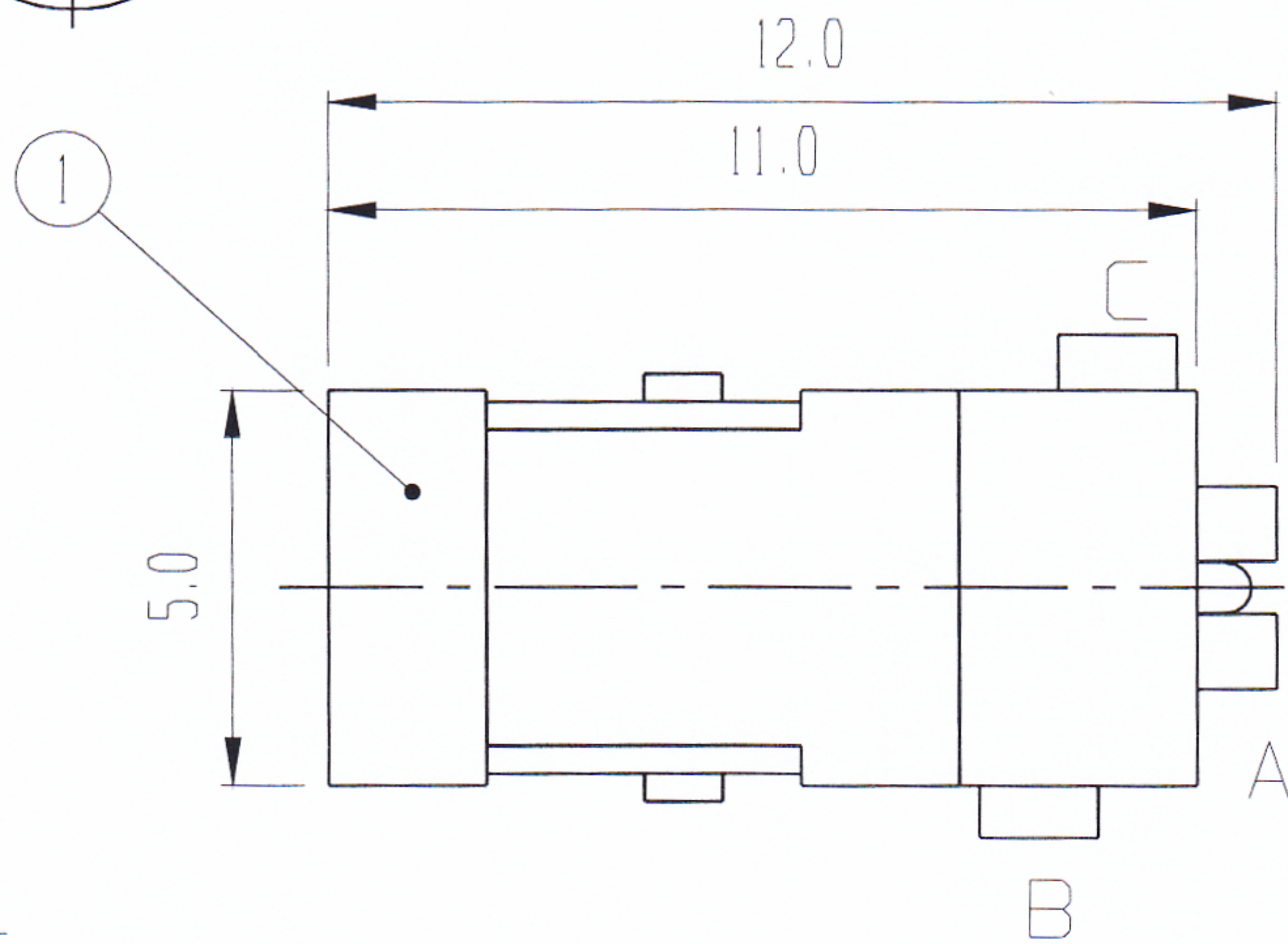

P.C.B. LAYOUT

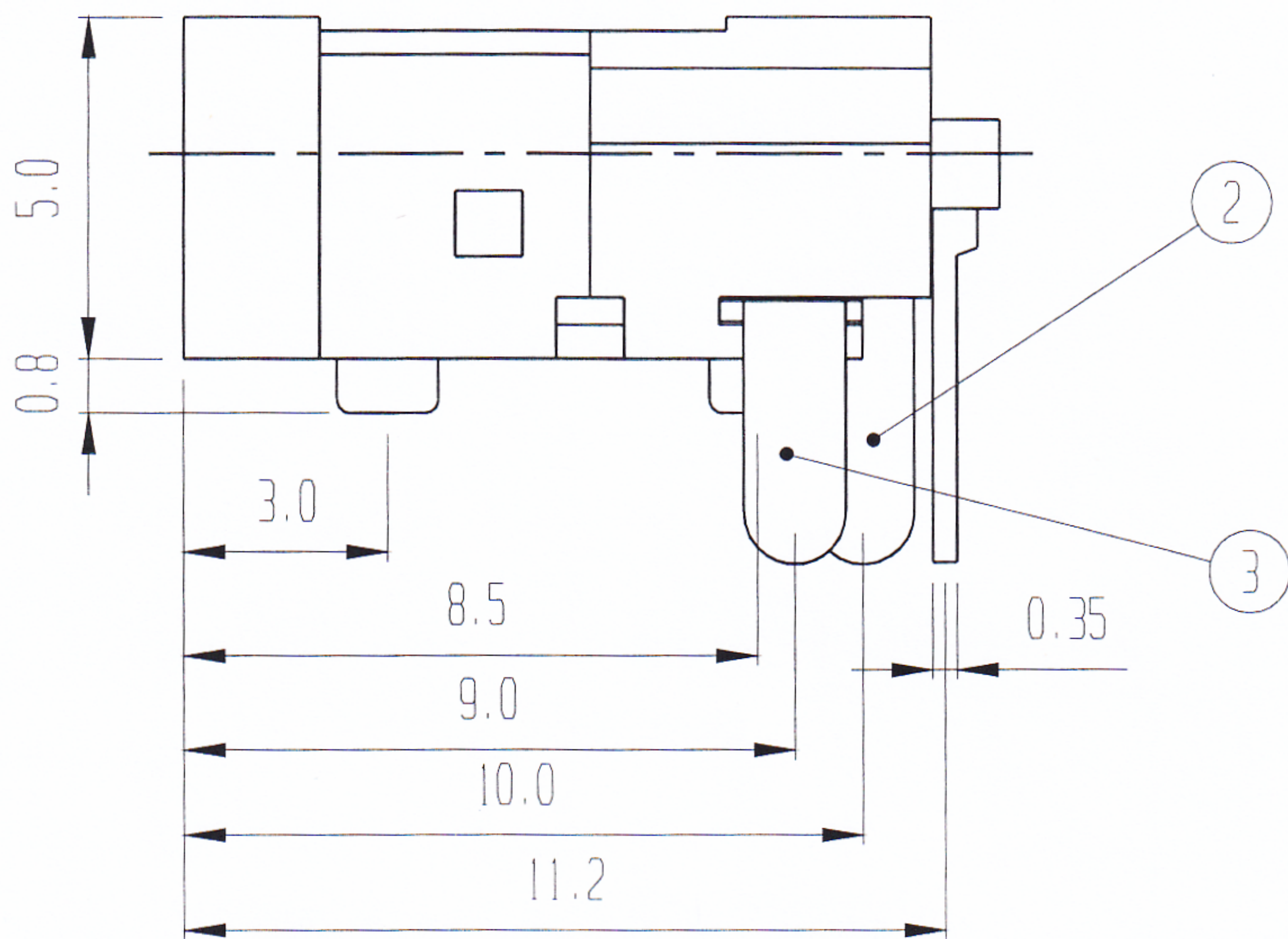
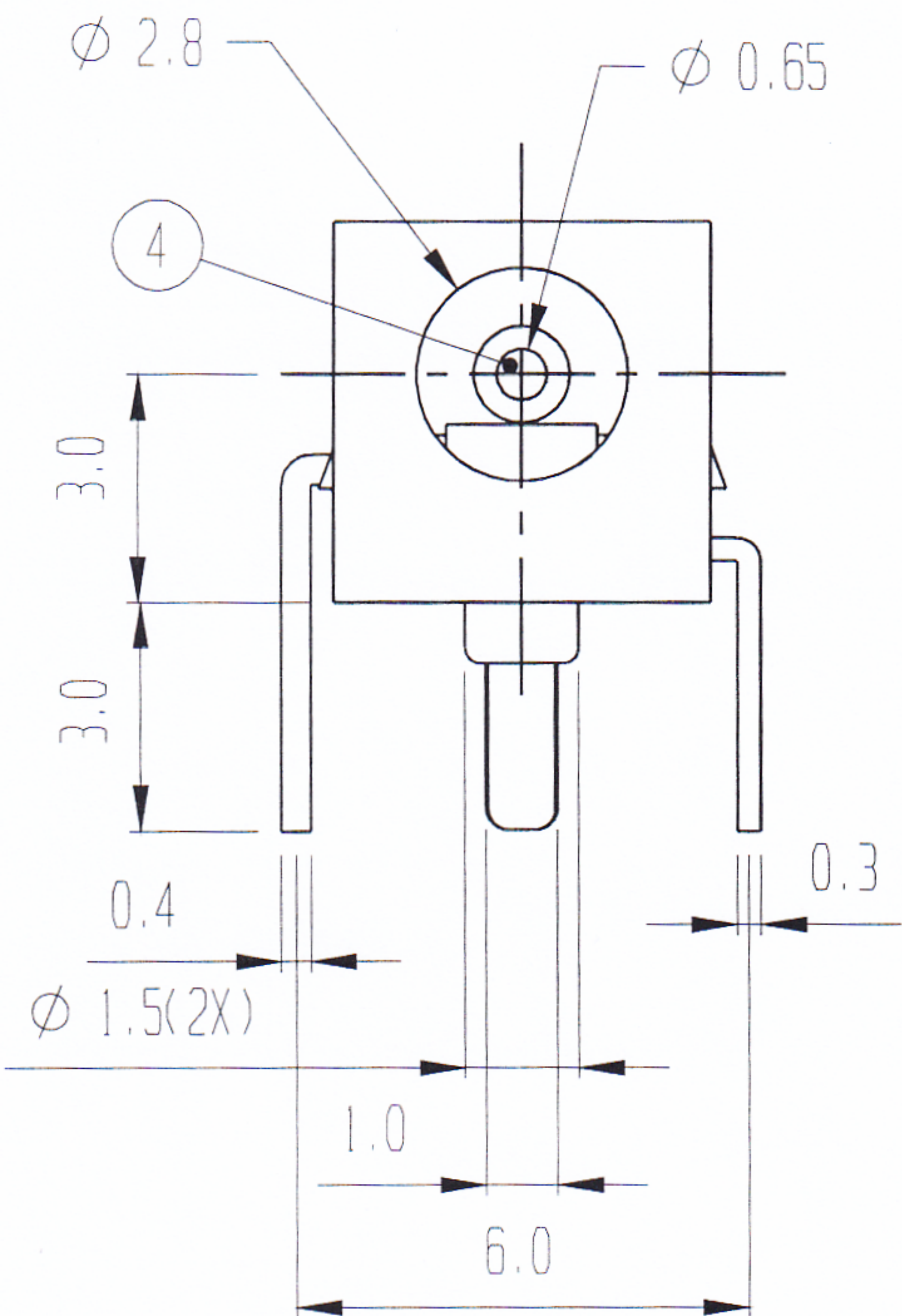

NO.	PART	MATERIAL	QTY	REMARKS	NO.	PART	MATERIAL	QTY	REMARKS
3	TERMINAL	P B S	1	Ag PLATED	4	CENTER PIN	BRASS	1	Ag PLATED
1	FRAME	P B T	1		2	TERMINAL	BRASS	1	Ag PLATED

ISSUED	SPECIFICATION	TITLE: DC POWER JACK		
	RATING: DC 30V 0.3A	MODEL NO: DC-027		
	CONTACT RESISTANCE: 50mΩ max.	TOLERANCE	UNIT: MM	DWN.
	INSULATION RESISTANCE: 100MΩ AT 500V DC	UP TO 1.0:±0.1	SCALE: 5:1	CHK'D.
	WITHSTAND VOLTAGE: AC 250V for 1 minute	1.0 TO 10.0:±0.2	VERSION: 04	APPD.
	OPERATION FORCE: REFER ATTACH SPECIFICATION	OVER 10.0:±0.3	DRWG NO:	
	SWITCHING LIFE: 5,000 cycles min.			